

821

Strainer



Body material	Nominal pressure	Nominal diameter	Max. temperature
A Grey cast iron	A 6 bar	DN 15-200	300°C*
	C 16 bar	DN 15-400	300°C*
C Nodular cast iron	C 16 bar	DN 15-200	350°C*
	D 25 bar	DN 15-200	350°C*
F Cast steel	E 40 bar	DN 15-200	450°C
I Stainless steel	E 40 bar	DN 15-200	400°C

* for epoxy versions max. temperature 80 ° C

CE correspond to the pressure equipment directive 2014/68/UE marking CE for DN≥32

FEATURES

- screen made of stainless steel (from DN 50 with reinforced ring, from DN 150 with supporting basket)
- compact settlement
- environment-friendly
- cleaning of screen without disassembling
- face-to-face dimension according to EN 558 series 1
- flanges drilled according to EN 1092-1 for body material F, I
- flanges drilled according to EN 1092-2 for body material A,C
- closing tightness according to EN -12266-1

APPLICATION

industries							
	INDUSTRY	SHIPBUILDING INDUSTRY	HEATING	POWER ENGINEERING			
	media						
		GLYCOL	INDUSTRIAL WATER	DIATHERMIC OIL	STEAM	COMPRESSED AIR	NEUTRAL FLUIDS

MATERIALS, DIMENSIONS

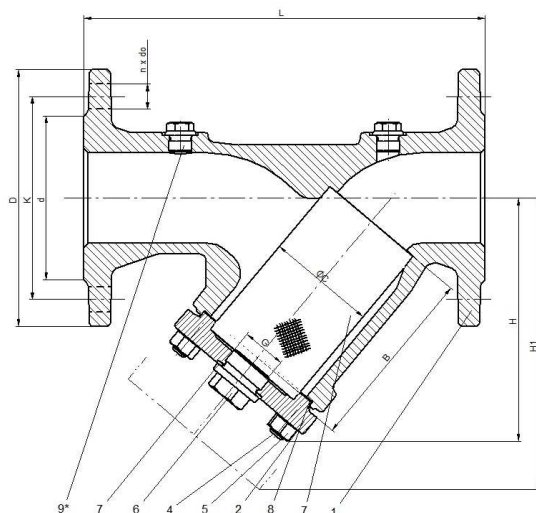

	Body material	A	C	F	I
1	Body	EN- GJL- 250 5.1301 (ex.JL 1040)	EN-GJS-400-18-LT 5.3103 (ex.JS 1025)	GP240GH 1.0619	G-X5CrNiMo19-11-2 1.4408
2	Cover	EN- GJL- 250 5.1301 (ex.JL 1040)	EN-GJS-400-18-LT 5.3103 (ex.JS 1025)	GP240GH 1.0619	G-X5CrNiMo19-11-2 1.4408
3	Screen	X5CrNi 18-10 1.4301			
3.1	Supporting basket	X5CrNi 18-10 1.4301 for DN ≥ 150			
4	Studs	5.6-A3A	A2-70	25CrMo4	A4-70
5	Hexagon nut	5-A3A	A2-70	25CrMo4	A4-70
6	Emptying screw	C35E			A2
7	Plug gasket	A4 1.4571			
8	Cover gasket	CrNiSt – Graphite			
9	Plug *,**	C35E			A2
Max. temperature		300°C	350°C	450°C	400°C

* position of the plug don't refer to PN 6

** plugs on client's request

DN	15	20	25	32	40	50	65	80	100	125	150	200	250	300	350	400	
L (mm)	130	150	160	180	200	230	290	310	350	400	480	600	730	850	980	1100	
H (mm)	90	100	115	135	150	160	180	215	240	280	330	405	540	680	755	835	
H1 (mm)	135	160	180	215	240	250	285	330	395	455	525	650	870	1110	1250	1370	
G (cal)	3/8	3/8	3/4	3/4	1	1	1	1	1 1/2	1 1/2	1 1/2	1 1/2	1 1/2	1 1/2	1 1/2	1 1/2	
C (mm)	23	28	36	42	50	61,5	78,5	89,5	109,5	137,5	160	210	258	308	365	415	
B (mm)	56	68	82	98	114	119	134	149	169	199	224	284	434	555	640	695	
Weight (kg)																	
821	PN6	2,2	2,8	3,9	5,7	7,3	8,4	13,5	17,7	25,3	37,5	49,0	98,0	-	-	-	-
	PN16	2,6	3,0	4,3	6,8	9,0	11,0	14,6	18,6	27,0	38,5	54,5	110,0	165,0	285,0	373,0	540,0
	PN25	2,6	3,0	4,3	6,8	9,0	11,0	16,8	19,5	29,6	42,5	56,0	110,0	-	-	-	-
	PN40	2,7	3,6	4,5	6,3	8,7	11,0	18,5	23,5	33,0	54,0	75,0	137,0	-	-	-	-

PRESSURE-TEMPERATURE RATINGS

Acc. EN 1092-2	PN				-10°C÷120°C	150°C	200°C	250°C	300°C	350°C	400°C	450°C
EN-GJL-250	6	bar	-----	---	6	5,4	4,8	4,2	3,6	---	---	---
	16		-----	---	16	14,4	12,8	11,2	9,6	---	---	---
EN-GJS-400-18 LT	16		-----	---	16	15,5	14,7	13,9	12,8	11,2	---	---
	25		-----	---	25	24,3	23	21,8	20	17,5	---	---
Acc. EN 1092-1			-40°÷<-10°C	-10°C÷50°C	100°C	150°C	200°C	250°C	300°C	350°C	400°C	450°C
GP240GH	40	bar	30	40	37,1	35,2	33,3	30,4	27,6	25,7	23,8	13,1
Acc. EN 1092-1				-60°÷<-10°C	-10°C÷100°C	150°C	200°C	250°C	300°C	350°C	400°C	450°C
G-X5CrNiMo19-11-2	40	bar		40	40	36,3	33,7	31,8	29,7	28,5	27,4	---

FLANGE DIMENSIONS ACC. PN-EN 1092-1/-2

DN		15	20	25	32	40	50	65	80	100	125	150	200	250	300	350	400
PN6	D (mm)	80	90	100	120	130	140	160	190	210	240	265	320	---	---	---	---
	K (mm)	55	65	75	90	100	110	130	150	170	200	225	280	---	---	---	---
	nxd (mm)	4x11	4x11	4x11	4x14	4x14	4x14	4x14	4x14	4x19	4x19	8x19	8x19	8x19	---	---	---
PN16	D (mm)	95	105	115	140	150	165	185	200	220	250	285	340	405	460	520	580
	K (mm)	65	75	85	100	110	125	145	160	180	210	240	295	355	410	470	525
	nxd (mm)	4x14	4x14	4x14	4x19	4x19	4x19	4x19	8x19	8x19	8x19	8x23	12x23	12x28	12x28	16x28	16x31
PN25	D (mm)	95	105	115	140	150	165	185	200	235	270	300	360	-----	-----	-----	-----
	K (mm)	65	75	85	100	110	125	145	160	190	220	250	310	-----	-----	-----	-----
	nxd (mm)	4x14	4x14	4x14	4x19	4x19	4x19	8x19	8x19	8x23	8x28	8x28	12x28	-----	-----	-----	-----
PN40	D (mm)	95	105	115	140	150	165	185	200	235	270	300	375	-----	-----	-----	-----
	K (mm)	65	75	85	100	110	125	145	160	190	220	250	320	-----	-----	-----	-----
	nxd (mm)	4x14	4x14	4x14	4x18	4x18	4x18	8x18	8x18	8x22	8x26	8x26	12x30	-----	-----	-----	-----

SCREENS

Screen	Type	DN	Mesh size	Mesh/cm2	Execution
Standard	F45	10-50	1,0	45	50
	F28	65-80	1,25	28	49
	F15	100-400	1,6	15	43
Other performance	screen cartridges F100 (0,6), F200 (0,5), F300 (0,4), F400 (0,32), F600 (0,25)				

* type with magnetic cartridge on client's request

HYDRAULIC CHARACTERISTIC

DN	15	20	25	32	40	50	65	80	100	125	150	200	250	300	350	400
Screen	$Kv_{sr.} [m^3/h]$															
Standard	6,3	11,2	14,7	23,7	37,7	57,9	101,5	147,4	209,6	326,2	403,0	707,0	1234,4	1916,2	2621,4	3460,3
F100 (0,63)	6,2	9,6	14,2	23,1	36,6	53,7	95,1	137,1	206,4	268,8	401,4	706,7	1229,4	1902,4	2611,0	3438,4
F200 (0,50)	6,2	9,5	14,1	23,0	35,6	53,0	92,7	133,4	202,7	314,3	462,3	811,0	1375,1	2133,1	2885,4	3747,0
F300 (0,40)	6,1	9,3	13,5	22,1	33,4	49,8	86,0	121,2	183,5	284,3	420,3	738,3	1274,3	2021,6	2698,8	3545,0
F400 (0,32)	6,0	9,1	13,2	21,7	33,4	48,5	82,9	115,9	173,7	268,8	401,4	706,7	1229,4	1902,4	2611,0	3438,4
F600 (0,25)	6,0	9,1	13,0	21,7	33,3	48,4	82,6	115,9	173,1	266,8	397,9	701,2	1225,0	1892,1	2606,8	3433,9

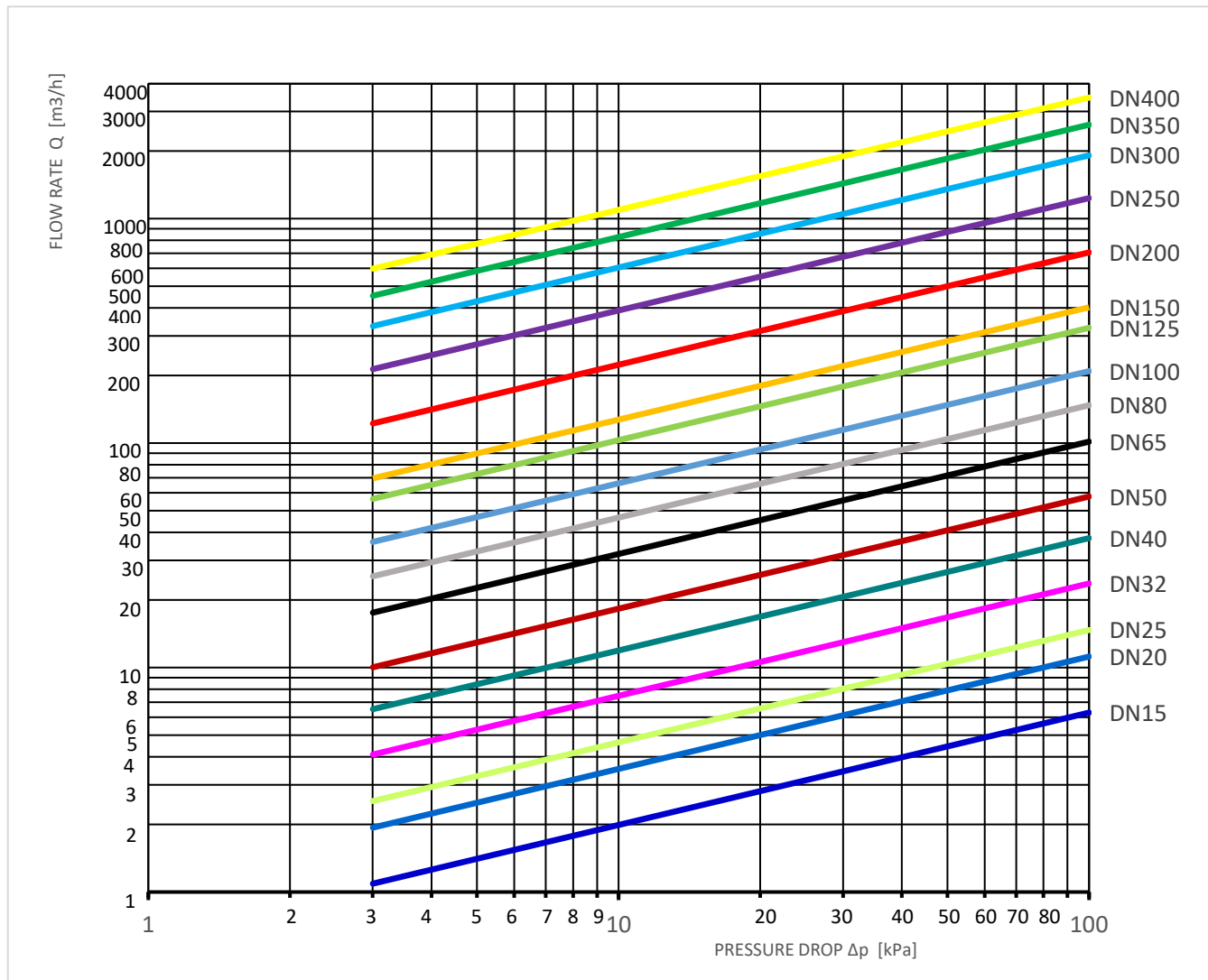

TYPE

Figure	Body material	Nominal diameter	Nominal pressure	Type
821	A Grey cast iron EN-GJL-250	15-50 mm	A 6 bar	mesh 1,00 mm, 45 mesh/cm ² 50
		65-80 mm	A 6 bar	mesh 1,25 mm, 28 mesh/cm ² 49
		100-200 mm	A 6 bar	mesh 1,60 mm, 15 mesh/cm ² 43
		15-200 mm	A 6 bar	mesh 0,63 mm, 100 mesh/cm ² 44
		15-200 mm	A 6 bar	mesh 0,50 mm, 200 mesh/cm ² 45
		15-200 mm	A 6 bar	mesh 0,40 mm, 300 mesh/cm ² 46
		15-200 mm	A 6 bar	mesh 0,32 mm, 400 mesh/cm ² 47
		15-200 mm	A 6 bar	mesh 0,25 mm, 600 mesh/cm ² 48
		15-50 mm	C 16 bar	mesh 1,00 mm, 45 mesh/cm ² 50
		65-80 mm	C 16 bar	mesh 1,25 mm, 28 mesh/cm ² 49
		100-400 mm	C 16 bar	mesh 1,60 mm, 15 mesh/cm ² 43
		15-400 mm	C 16 bar	mesh 0,63 mm, 100 mesh/cm ² 44
		15-400 mm	C 16 bar	mesh 0,50 mm, 200 mesh/cm ² 45
		15-400 mm	C 16 bar	mesh 0,40 mm, 300 mesh/cm ² 46
		15-400 mm	C 16 bar	mesh 0,32 mm, 400 mesh/cm ² 47
		15-400 mm	C 16 bar	mesh 0,25 mm, 600 mesh/cm ² 48
		15-50 mm	C 16 bar	mesh 1,00 mm, 45 mesh/cm ² , with magnetic cartridge 70
		65-80 mm	C 16 bar	mesh 1,25 mm, 28 mesh/cm ² , with magnetic cartridge 69
		100-400 mm	C 16 bar	mesh 1,60 mm, 15 mesh/cm ² , with magnetic cartridge 63
		15-50 mm	C 16 bar	mesh 1,00 mm, 45 mesh/cm ² , epoxy paint 50-D

			65-80 mm	C 16 bar	mesh 1,25 mm, 28 mesh/cm ² , epoxy paint	49-D
			100-400 mm	C 16 bar	mesh 1,60 mm, 15 mesh/cm ² , epoxy paint	43-D
			15-400 mm	C 16 bar	mesh 0,63 mm, 100 mesh/cm ² , epoxy paint	44-D
			15-400 mm	C 16 bar	mesh 0,50 mm, 200 mesh/cm ² , epoxy paint	45-D
			15-400 mm	C 16 bar	mesh 0,40 mm, 300 mesh/cm ² , epoxy paint	46-D
			15-400 mm	C 16 bar	mesh 0,32 mm, 400 mesh/cm ² , epoxy paint	47-D
			15-400 mm	C 16 bar	mesh 0,25 mm, 600 mesh/cm ² , epoxy paint	48-D
821	C Nodular cast iron EN-GJS-400-18-LT		15-50 mm	C 16 bar	mesh 1,00 mm, 45 mesh/cm ²	50
			65-80 mm	C 16 bar	mesh 1,25 mm, 28 mesh/cm ²	49
			100-200 mm	C 16 bar	mesh 1,60 mm, 15 mesh/cm ²	43
			15-200 mm	C 16 bar	mesh 0,63 mm, 100 mesh/cm ²	44
			15-200 mm	C 16 bar	mesh 0,50 mm, 200 mesh/cm ²	45
			15-200 mm	C 16 bar	mesh 0,40 mm, 300 mesh/cm ²	46
			15-200 mm	C 16 bar	mesh 0,32 mm, 400 mesh/cm ²	47
			15-200 mm	C 16 bar	mesh 0,25 mm, 600 mesh/cm ²	48
			15-50 mm	D 25 bar	mesh 1,00 mm, 45 mesh/cm ²	50
			65-80 mm	D 25 bar	mesh 1,25 mm, 28 mesh/cm ²	49
			100-200 mm	D 25 bar	mesh 1,60 mm, 15 mesh/cm ²	43
			15-200 mm	D 25 bar	mesh 0,63 mm, 100 mesh/cm ²	44
			15-200 mm	D 25 bar	mesh 0,50 mm, 200 mesh/cm ²	45
			15-200 mm	D 25 bar	mesh 0,40 mm, 300 mesh/cm ²	46
			15-200 mm	D 25 bar	mesh 0,32 mm, 400 mesh/cm ²	47

821	F Cast steel GP240GH	15-200 mm	D 25 bar	mesh 0,25 mm, 600 mesh/cm ²	48
		15-50 mm	E 40 bar	mesh 1,00 mm, 45 mesh/cm ²	50
		65-80 mm	E 40 bar	mesh 1,25 mm, 28 mesh/cm ²	49
		100-200 mm	E 40 bar	mesh 1,60 mm, 15 mesh/cm ²	43
		15-200 mm	E 40 bar	mesh 0,63 mm, 100 mesh/cm ²	44
		15-200 mm	E 40 bar	mesh 0,50 mm, 200 mesh/cm ²	45
		15-200 mm	E 40 bar	mesh 0,40 mm, 300 mesh/cm ²	46
		15-200 mm	E 40 bar	mesh 0,32 mm, 400 mesh/cm ²	47
		15-200 mm	E 40 bar	mesh 0,25 mm, 600 mesh/cm ²	48
821	I Stainless steel G-X5CrNiMo19-11-2	15-50 mm	E 40 bar	mesh 1,00 mm, 45 mesh/cm ²	50
		65-80 mm	E 40 bar	mesh 1,25 mm, 28 mesh/cm ²	49
		100-200 mm	E 40 bar	mesh 1,60 mm, 15 mesh/cm ²	43
		15-200 mm	E 40 bar	mesh 0,63 mm, 100 mesh/cm ²	44
		15-200 mm	E 40 bar	mesh 0,50 mm, 200 mesh/cm ²	45
		15-200 mm	E 40 bar	mesh 0,40 mm, 300 mesh/cm ²	46
		15-200 mm	E 40 bar	mesh 0,32 mm, 400 mesh/cm ²	47
		15-200 mm	E 40 bar	mesh 0,25 mm, 600 mesh/cm ²	48

ORDERING

Figure	Body material	Nominal diameter	Nominal pressure	Type
821	A Grey cast iron EN-GJL-250	15-50 mm	A 6 bar	50 mesh 1,00 mm, 45 mesh/cm ²

Order example acc. index

821 A 050 C 50

Strainer, ends flanged, form Y-tape

Grey cast iron EN-GJL-250

Nominal diameter (mm)

Nominal pressure PN 16

Mesh 1,00 mm, 45 mesh/cm²

821 A 050 C 50