

Series BCP

1933181000

General series information
AVENTICS Series BCP Bellow actuators

- The AVENTICS Series BCP cylinders are bellow actuators with firmly flanged steel covers and bellows made of natural rubber in the standard version. The heat-resistant version is distinguished by bellows made of epichlorohydrin rubber (ECO) and the corrosion-resistant version by stainless steel covers (V2A).

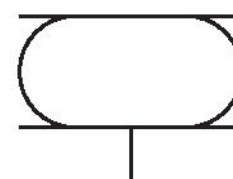

Technical data

Industry	Industrial
Bellows	double
Type	Bellow actuator with cover
Functional principle	Single-acting, retracted without pressure
Compressed air connection	G 3/4
Cover diameter	228 mm
Permissible angle of tilt max.	20 °
Max. effective stroke	190 mm
Min. radial installation space	340 mm
Installation height, min.	75 mm
Installation height, max.	265 mm
Force min.	17000 N
Force max.	35400 N
Working pressure min.	0 bar
Working pressure max.	8 bar

Min. ambient temperature	-40 °C
Max. ambient temperature	70 °C
Medium	Compressed air
Reduced service life at a temperature greater than	50 °C
Pressure for determining forces	6 bar
Weight	4.8 kg

Material

Material bellow	caoutchouc/butadiene caoutchouc
Material front cover	Steel, chrome-plated
Surface cover	galvanized
Part No.	1933181000

Technical information

Compliance with the minimum height H min. as well as the maximum height H max. must be ensured with end stops.

Use at operating height $\geq H_{max}$: only permitted upon approval by AVENTICS

Further information on vibration isolation can be found in the "Technical information" document (available in the MediaCentre).

The pressure dew point must be at least 15 °C less than ambient and medium temperature and may not exceed 3 °C.

The oil content of compressed air must remain constant during the life cycle.

Use only the approved oils from AVENTICS. Further information can be found in the "Technical information" document (available in <https://www.emerson.com/en-us/support>).

Dimensions

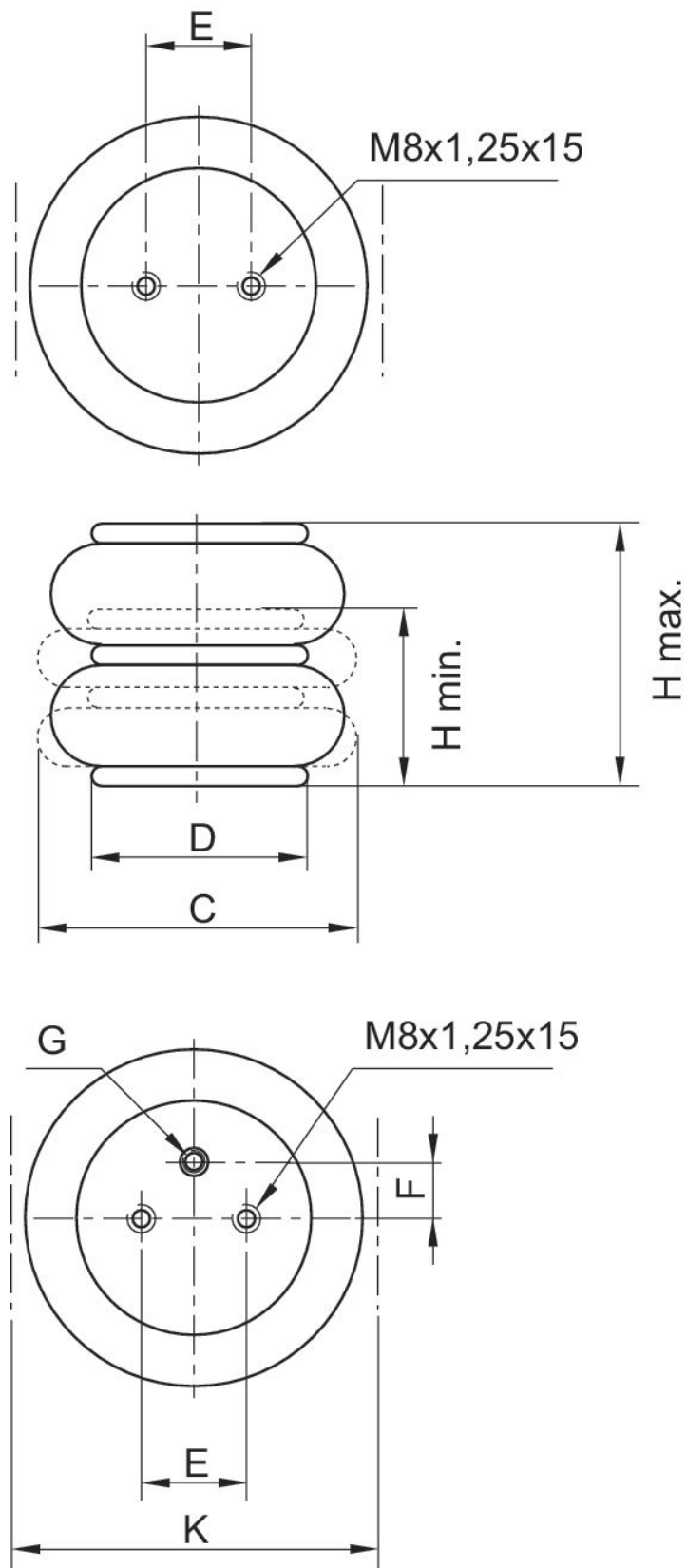

Part No.	Compressed air connection G	H min. mm	H max. mm	C mm	D mm	E ±0,5 [mm]	F ±0,5 [mm]	K mm	Return force, min. N
0822419043	G 3/4	75	240	250	161	89	38.1	250	200
R412010042	G 3/4	77	260	255	161	89	38.1	265	200
2999619400	G 3/4	77	300	260	161	89	38.1	275	250
1933181000	G 3/4	75	265	325	228	157.5	73	340	300
2999638300	G 3/4	77	300	340	228	157.5	73	355	300

Comment

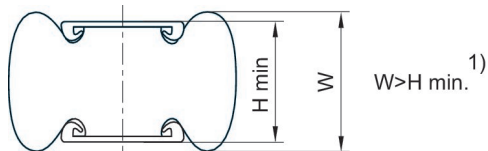

1) Once the minimum height H min. is reached, the bead height W can fall below the lower limit. If, for these products, level mounting surfaces greater than the cover diameter are selected, the return force and force output at the start of stroke increase. In the process, the rubber bellow is also compressed by the mounting surfaces. These products require more space upward, which can, in rare cases, present a hindrance. In any case, the specifications of the data sheets apply when using mounting surfaces in the size of the bellows actuator cover.
1 kN = 1000 N

Force-displacement diagram 1933181000

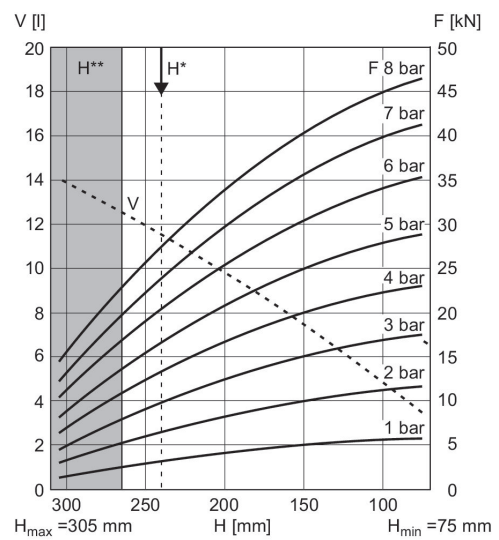

V = volume H = height H* = recommended operating height for vibration isolation H** = use permitted only upon approval by AVENTICS
1 kN = 1000 N