

# Piston rod cylinders, Series 102

1028300000

## General series information

AVENTICS Series 102 Diaphragm type cylinder

- The AVENTICS Series 102 is cost-efficient solution to generate high forces for press application for example.

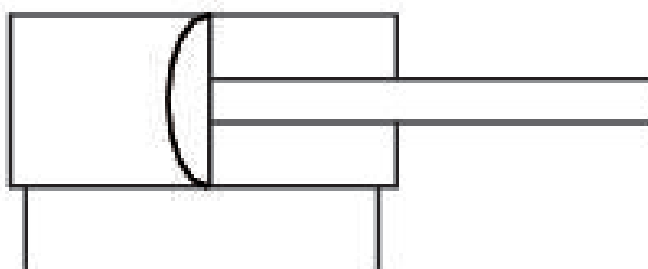

## Technical data

Industry	Industrial
Piston Ø	250 mm
Stroke	80 mm
Ports	G 1/2
Functional principle	Double-acting
Pressure for determining piston forces	6 bar
Retracting piston force	24300 N
Extracting piston force	25000 N
Min. ambient temperature	-20 °C
Max. ambient temperature	70 °C
Working pressure min.	2 bar
Working pressure max	8 bar

Piston rod thread	M24
Weight	21.6 kg
Medium	Compressed air
Min. medium temperature	-20 °C
Max. medium temperature	70 °C
Max. particle size	50 µm
Oil content of compressed air min.	0 mg/m <sup>3</sup>
Oil content of compressed air max.	5 mg/m <sup>3</sup>

## Material

Piston rod	Steel, chrome-plated
Seal material	Acrylonitrile butadiene rubber
Material, front cover	Steel, chrome-plated
Cylinder tube	Steel, chrome-plated
Part No.	1028300000

## Technical information

Tolerance at 40 mm, 50 mm, 80 mm stroke:  $\pm 3$  mm

The pressure dew point must be at least 15 °C less than ambient and medium temperature and may not exceed 3 °C.

The oil content of compressed air must remain constant during the life cycle.

Use only the approved oils from AVENTICS. Further information can be found in the "Technical information" document (available in <https://www.emerson.com/en-us/support>).

## Dimensions

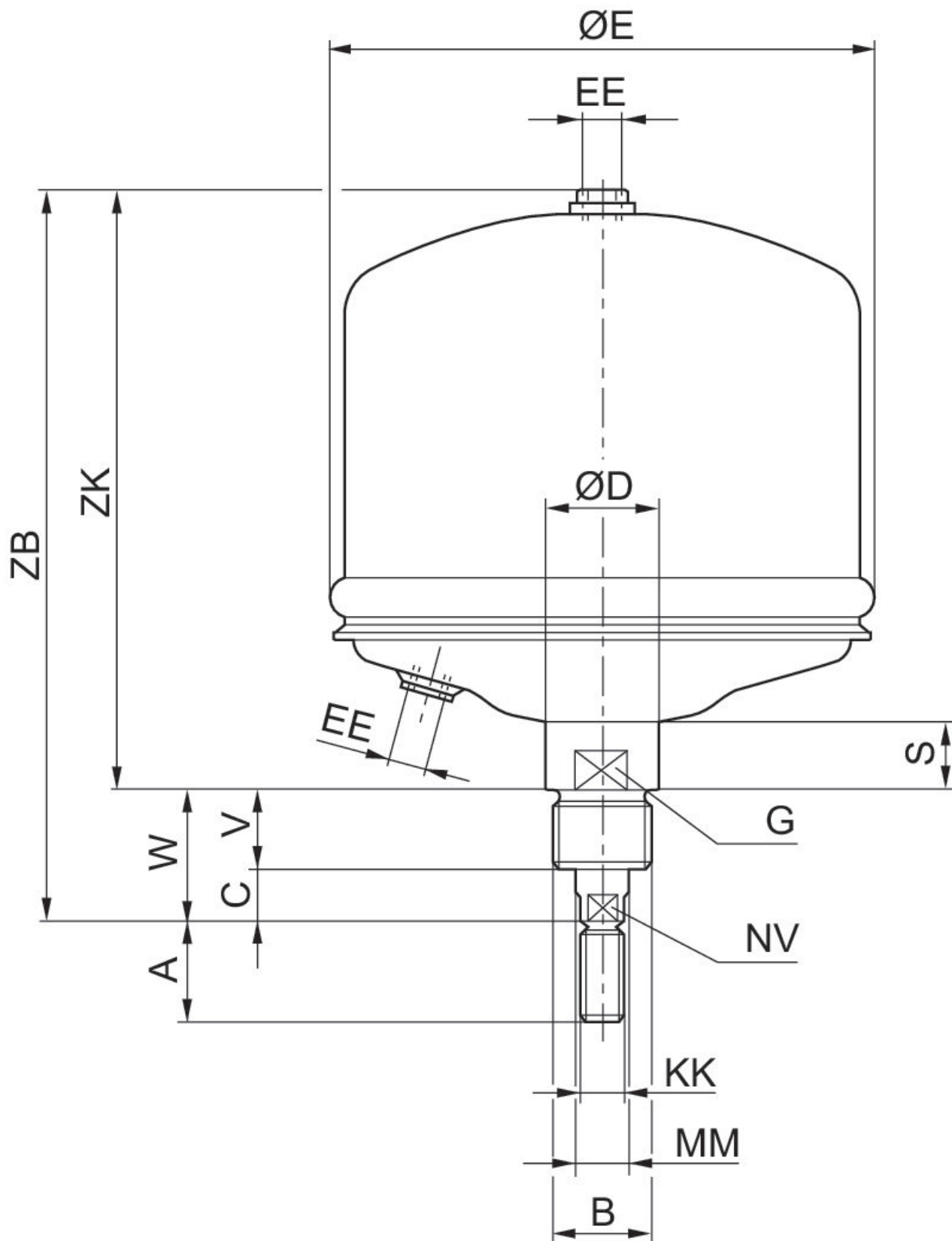

Part No.	Piston Ø	A	B	C	D	E	G	S	V
1028300000	250	48	M48x3	20	56	268	50	33	40

Part No.	Piston Ø	W	EE	KK	MM	NV	ZB	ZK
1028300000	250	60	G 1/2	M24	28	25	385	325

## Overview drawing

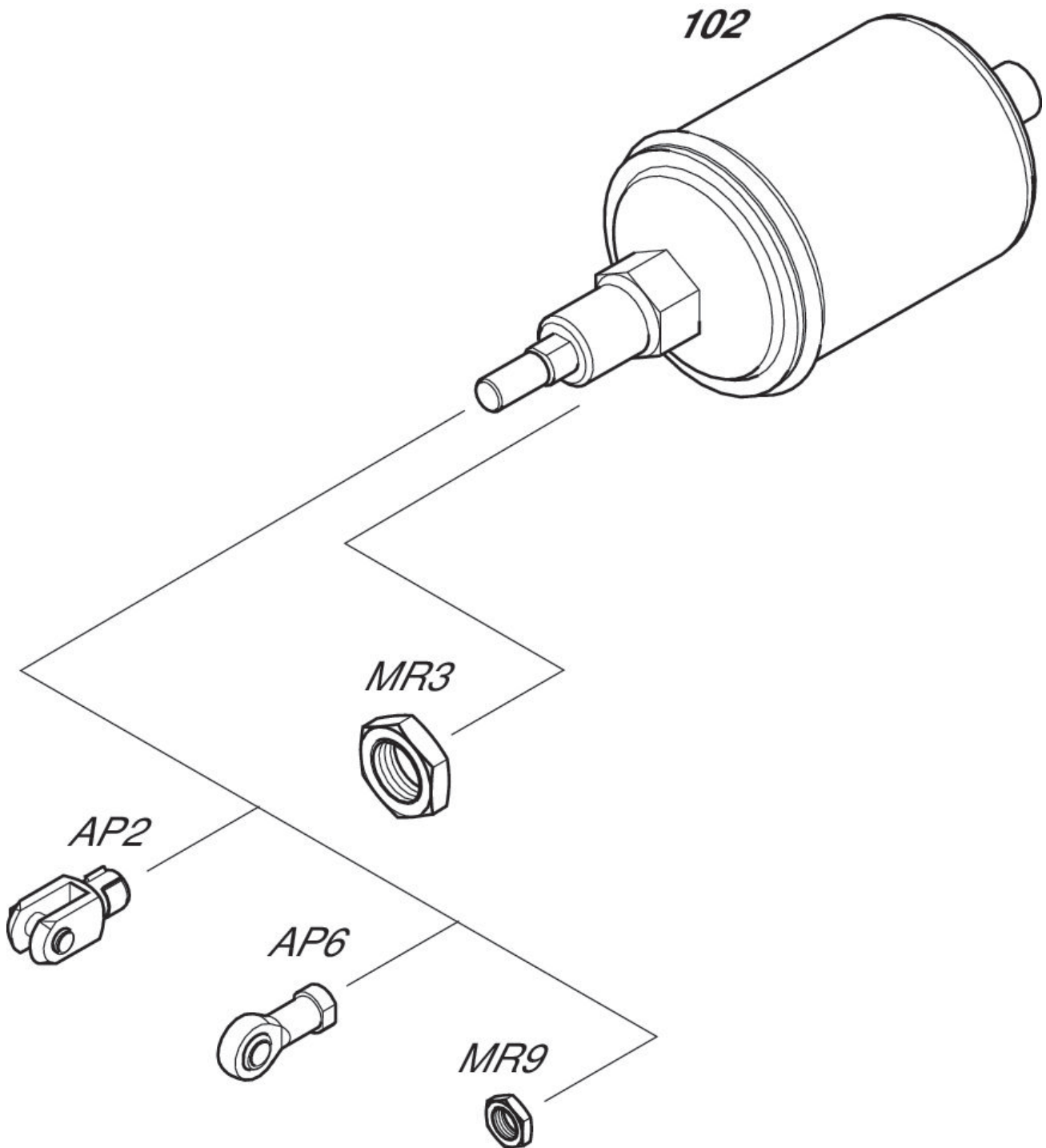

NOTE: This overview drawing is only for orientation to indicate where the various accessory parts can be fastened to the cylinder. The illustration has been simplified for this purpose. It is thus not possible to derive the dimensions from this overview.