

# 3/2-directional valve, Series AP

2023-11-27

0820402105

## Series AP - inch

Qn = [[150 ... 250] l/min]

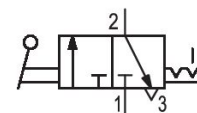

## Technical data

Industry

Industrial

Activation

Mechanical

Valve type

Poppet valve

Plate connection

Pipe connection

Actuating element

Lever

Compressed air connection type

Internal thread

Compressed air connection input

G 1/8

Compressed air connection output

G 1/8

Compressed air connection, exhaust

G 1/8

Nominal flow Qn 1 to 2

250 l/min

Nominal flow Qn 2 to 3

150 l/min

Min. working pressure

0 bar

Max. working pressure

10 bar

Min. ambient temperature

-30 °C

Max. ambient temperature

80 °C

Min. medium temperature

-30 °C

Max. medium temperature

80 °C

Medium

Compressed air

# 3/2-directional valve, Series AP

2023-11-27

0820402105

---

Min. oil content of compressed air	0 mg/m <sup>3</sup>
Max. oil content of compressed air	5 mg/m <sup>3</sup>
Max. particle size	5 μm

Weight 0.075 kg

## Material

Housing material	Aluminum
Seal material	Acrylonitrile butadiene rubber
Part No.	0820402105

## Technical information

The min. control pressure must be adhered to, since otherwise faulty switching and valve failure may result!

The pressure dew point must be at least 15 °C less than ambient and medium temperature and may not exceed 3 °C.

The oil content of compressed air must remain constant during the life cycle.

Use only the approved oils from AVENTICS. Further information can be found in the "Technical information" document (available in <https://www.emerson.com/en-us/support>).

# 3/2-directional valve, Series AP

2023-11-27

0820402105

## Dimensions

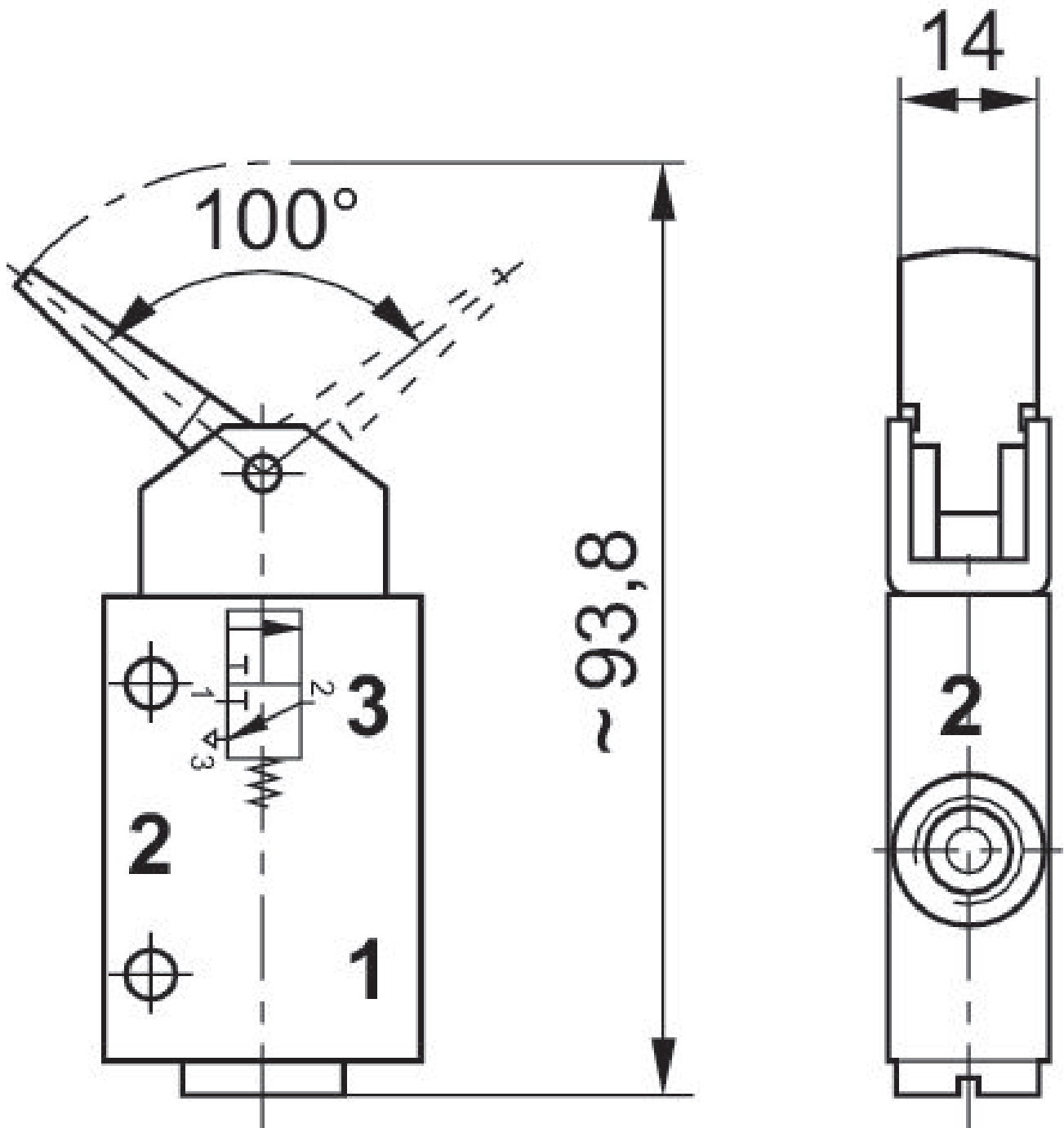

# 3/2-directional valve, Series AP

2023-11-27

0820402105

## Actuating force+

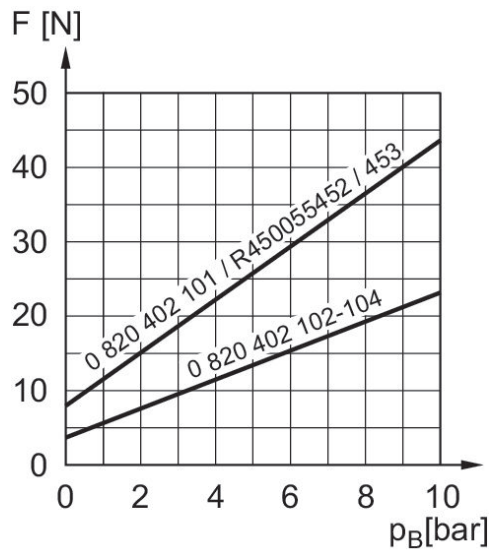

F = actuating force  
 $p_B$  = Working pressure